

Double Worm Reducer

2단 웜 감속기

MODEL	축배치 및 회전방향	도	면
-------	------------	---	---

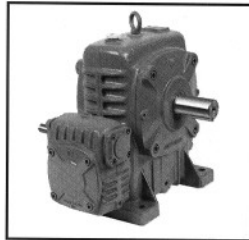

DWB-80

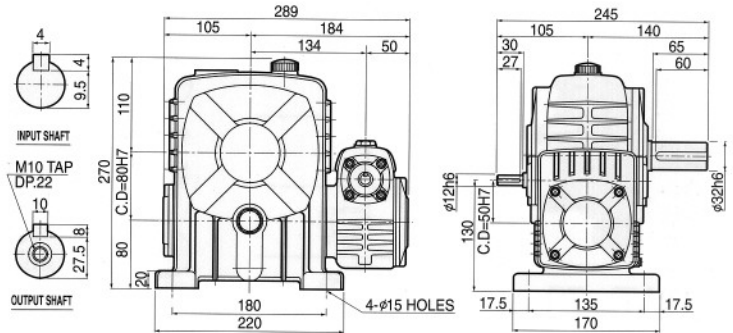
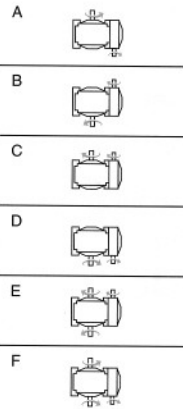

DWV-80

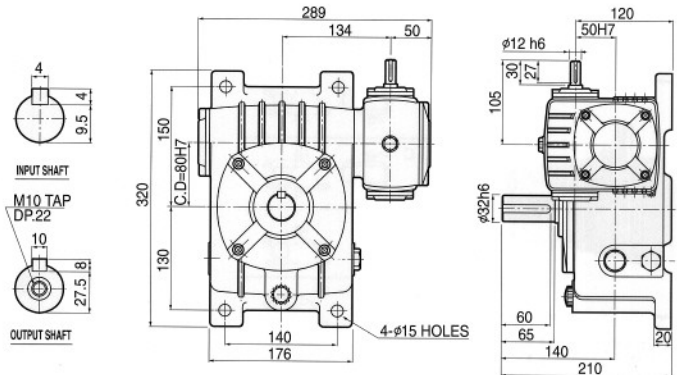
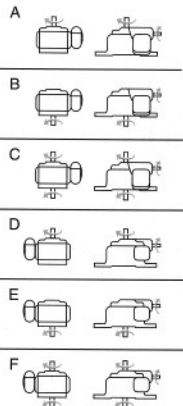

전동능력표

수치는 1일 8~10시간 연속 운전이고 균일 하중의 수치입니다.

INPUT rpm RATIO	1800				1500				1200			
	INPUT HP	OUTPUT HP	OUTPUT T kgf-m	OUTPUT O.H.L kgf	INPUT HP	OUTPUT HP	OUTPUT T kgf-m	OUTPUT O.H.L kgf	INPUT HP	OUTPUT HP	OUTPUT T kgf-m	OUTPUT O.H.L kgf
1/200	0.89	0.41	33.8	400	0.64	0.36	35.0	400	0.53	0.28	35.0	400
1/300	0.64	0.28	35.0	400	0.45	0.24	35.0	400	0.37	0.19	35.0	400
1/400	0.53	0.20	35.0	400	0.36	0.17	35.0	400	0.28	0.13	35.0	400
1/500	0.44	0.16	35.0	400	0.29	0.13	35.0	400	0.24	0.11	35.0	400
1/600	0.39	0.13	35.0	400	0.27	0.12	35.0	400	0.20	0.08	35.0	400
1/800	0.45	0.09	35.0	400	0.28	0.08	35.0	400	0.23	0.07	35.0	400
1/900	0.29	0.08	35.0	400	0.21	0.08	35.0	400	0.16	0.05	35.0	400

INPUT rpm RATIO	900				600			
	INPUT HP	OUTPUT HP	OUTPUT T kgf-m	OUTPUT O.H.L kgf	INPUT HP	OUTPUT HP	OUTPUT T kgf-m	OUTPUT O.H.L kgf
1/200	0.40	0.21	35.0	400	0.28	0.14	35.0	400
1/300	0.28	0.14	35.0	400	0.19	0.09	35.0	400
1/400	0.21	0.10	35.0	400	0.16	0.07	35.0	400
1/500	0.17	0.08	35.0	400	0.12	0.04	35.0	400
1/600	0.16	0.07	35.0	400	0.09	0.04	35.0	400
1/800	0.16	0.05	35.0	400	0.11	0.03	35.0	400
1/900	0.12	0.04	35.0	400	0.09	0.03	35.0	400