

## Average Breaking Load

### 평균 파단 강도 집계표

unit : mm

DONG BO Chain No.	Standard Series	Semi Heavy Series	Heavy Series	Stainless Steel 400 Series		Stainless 300 Series	Heavy & Extra Wear Life Series	Wear Resistant Series	Special type
	보통형	준강력형	강력형	스테인레스 400 시리즈	스테인레스 400 시리즈	스테인레스 300 시리즈	강력·내마모시리즈	내마모시리즈	응용시리즈
	N	SH	H	SB	SBN	SA	CH	CN, CB	WA, WB
DBC 03075 DBC 03100 DBC 03150	3,000	4,600	7,100	3,500	5,500	3,400	5,200	3,800	7,100
DBC 430	5,500	7,600	10,000	5,300	8,500	4,900	7,100	5,800	10,000
DBC 05075 DBC 05100 DBC 05150	7,000	9,800	14,500	7,200	11,000	7,000	10,000	7,900	14,500
DBC 204	8,000	10,500	14,500	8,000	12,500	7,000	10,000	8,800	14,500
DBC 450	8,000	10,500	14,500	8,000	12,500	7,000	10,000	8,800	14,500
DBC 08125 DBC 08150	8,000	10,500	14,500	8,000	12,500	7,000	10,000	8,800	14,500
DBC 650	8,000	10,500	14,500	14,000	14,500	7,000	10,000	14,500 (CN, 10,000)	14,500
DBC 10100 DBC 10125 DBC 10150	11,500	16,000	23,000	11,500	18,000	11,000	23,000	12,500	23,000
DBC 214	13,000	18,000	24,500	12,000	19,000	12,500	24,500	13,000	24,500
DBC 205	13,000	18,000	24,500	12,000	19,000	12,500	24,500	13,000	24,500
DBC 6205	19,000	24,000	28,500	17,000	27,000	13,500	28,500	19,000	28,500
DBC 12200 DBC 12250	19,000	24,000	28,500	17,000	27,000	13,500	28,500	19,000	28,500
DBC 17200 DBC 17250 DBC 17300	25,000	31,000	39,500	22,500	36,500	19,000	39,500	25,000	39,500
DBC 212	21,000	31,000	39,500	22,500	36,500	19,000	39,500	21,000	39,500
DBC 26200 DBC 26250 DBC 26300 DBC 26450	32,000	43,000	53,000	30,000	47,000	25,500	53,000	32,000	53,000
DBC 36250 DBC 36300 DBC 36450 DBC 36600	48,500	67,000	69,500	-	-	-	69,500	48,500	69,500
DBC 52300 DBC 52450 DBC 52600	54,000	105,000	105,000	-	-	-	105,000	54,000	105,000
DBC 60300 DBC 60350 DBC 60400	62,000	-	106,000	-	-	-	106,000	62,000	106,000
DBC 90350 DBC 90400 DBC 90500	95,000	-	166,000	-	-	-	166,000	95,000	166,000
DBC 120400 DBC 120600	113,000	-	225,000	-	-	-	225,000	113,000	225,000

Note) Please refer to the Bucket Elevator Chain page for DBC26~ and DBC36~ Series (N-type)

주) DBC 26~시리즈와 DBC 36~ 시리즈의 보통형(N형)은 '버킷엘리베이터용 체인' 페이지를 참조하십시오.

## Comparative Table of Standard Conveyor Chain

### 표준형 컨베이어 체인번호 비교표

DONG BO Chain No.		HITACHI	TSUBAKI	DAIDO
<b>DBC</b>	<b>430</b>	HR 10105	RF 430	DK 4008
<b>DBC</b>	<b>204</b>	HR 66081	RF 204	DK 4004
<b>DBC</b>	<b>450</b>	HR 10108	RF 450	DK 4009
<b>DBC</b>	<b>650</b>	HR 15208	RF 650	DK 4018
<b>DBC</b>	<b>10100</b>	HR 10011	RF 10100	-
<b>DBC</b>	<b>10125</b>	HR 12511	RF 10125	-
<b>DBC</b>	<b>10150</b>	HR 15211	RF 10150	DK 3019
<b>DBC</b>	<b>214</b>	HR 10113	RF 214	DK 4012
<b>DBC</b>	<b>6205</b>	HR 15215	RF 6205	DK 4022
<b>DBC</b>	<b>12200</b>	HR 20015	RF 12200	DK 3081
<b>DBC</b>	<b>12250</b>	HR 25015	RF 12250	DK 3082
<b>DBC</b>	<b>212</b>	HR 15219	RF 212	DK 4020
<b>DBC</b>	<b>17200</b>	HR 20019	RF 17200	DK 3085
<b>DBC</b>	<b>17250</b>	HR 25019	RF 17250	DK 3086
<b>DBC</b>	<b>17300</b>	HR 30019	RF 17300	DK 3087
<b>DBC</b>	<b>26200</b>	HR 20026	RF 26200	-
<b>DBC</b>	<b>26250</b>	HR 25026	RF 26250	DK 3091
<b>DBC</b>	<b>26300</b>	HR 30026	RF 26300	DK 3092
<b>DBC</b>	<b>26450</b>	HR 45026	RF 26450	-
<b>DBC</b>	<b>36250</b>	HR 25048	RF 36250	-
<b>DBC</b>	<b>36300</b>	HR 30048	RF 36300	DK 3096
<b>DBC</b>	<b>36450</b>	HR 45048	RF 36450	DK 3097
<b>DBC</b>	<b>36600</b>	HR 60048	RF 36600	-
<b>DBC</b>	<b>52300</b>	HR 30054	RF 52300	-
<b>DBC</b>	<b>52450</b>	HR 45054	RF 52450	-
<b>DBC</b>	<b>52600</b>	HR 60054	RF 52600	-

# Standard Conveyor Chain | 표준형 컨베이어 체인 |

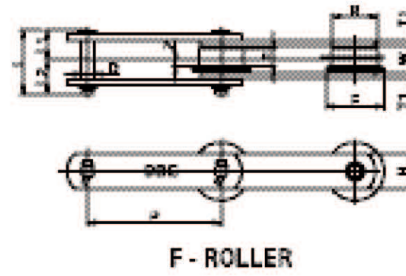
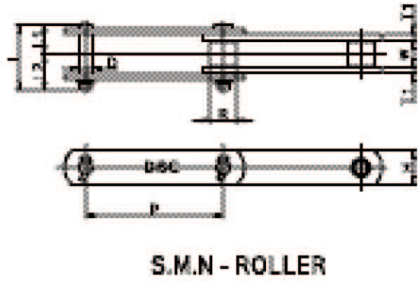

## Chain Dimensions

unit : mm

DONG BO Chain No.		Pitch	Inner width	Plate		Pin				Avg. Breaking Load kgf	
Basic Chain No.	Roller Type	P	W	T	H	D	L1	L2	L	Standard Serie	Heavy Series
DBC 03075 03100 03150	R · F · S	75 100 150	16.1	3.2	22	7.9	17.5	19.5	37	3,000	7,100
DBC 430	R · S	101.6	22.6	4.8(5.0)	25.4	9.7	25.5	29.5	55	5,500	10,000
DBC 05075 05100 05150	S R · F · S R · F · S	75 100 150	22	4.5	32	11.1	24.6	29.6	54.2	7,000	14,500
DBC 204	S	66.27	27	6.3(6.0)	28.6	11.1	30.7	35.6	66.3	8,000	14,500
DBC 450	R · F · S · M	101.6	27	6.3(6.0)	28.6	11.1	30.7	35.6	66.3	8,000	14,500
DBC 08125 08150	R · F · S · M	125 150	27	6.3(6.0)	28.6	11.1	30.7	35.6	66.3	8,000	14,500
DBC 650	R · F · S · M	152.4	30.2	6.3(6.0)	38.1	11.1	32.3	37.3	69.6	8,000	14,500
DBC 10100 10125 10150	R · S · M R · F · S · M R · F · S · M	100 125 150	30	6.3(6.0)	38.1	14.3	32.7	39.2	71.9	11,500	23,000
DBC 214	R · S · M	101.6	31.6	7.9	38.1	15.9	37.2	43.7	80.9	13,000	24,500
DBC 205	S	78.11	37.1	7.9	38.1	15.9	40	46.4	86.4	13,000	24,500
DBC 6205	R · F · S · M	152.4	37.1	7.9	44.5	15.9	40	46.4	86.4	19,000	28,500
DBC 12200 12250	R · F · S · M	200 250	37.1	7.9	44.5	15.9	40	46.4	86.4	19,000	28,500
DBC 17200 17250 17300	R · F · S · M	200 250 300	51.4	9.5(10.0)	50.8	19.05	51.5	60	111.5	25,000	39,500
DBC 212	R · S · M	152.4	37.1	9.5(10.0)	50.8	19.05	44.2	57.7	96.9	21,000	39,500
DBC 26200 26250 26300 26350 26450	S · M R · F · S · M R · F · S · M R · F · S · M	200 250 300 450	57.2	9.5(10.0)	63.5	22.2	55.2	62.7	117.9	32,000	53,000
DBC 36250 36300 36450 36600	S · M R · F · S · M R · F · S · M R · F · S · M	250 300 450 600	66.7	12.7	76.2	25.4	68	76	144	48,500	69,500
DBC 52300 52450 52600	R · F · S	300 450 600	77	16	76.2	31.8	81.5	91.5	173	54,000	105,000
DBC 60300 60350 60400	R · F · N	300 350 400	77	12.7	90	35	77	84	161	62,000	106,000
DBC 90350 90400 90500	N R · F · N R · F · N	350 400 500	88	16	110	42.0	90	100	190	95,000	166,000
DBC 120400 120600	R · N R · F · N	400 600	100	19	130	50.0	106	113	219	113,000	225,000

Note) The Stainless steel Series are up to 26000. Numbers in brackets of the Link Plate thickness indicates the Stainless steel 300 Series.

The Number outside brackets is common for every series.

주) 스테인레스 시리즈는 26000까지이며 링크플레이트 두께의 ( ) 내 치수는 스테인레스 300시리즈를 표시한 것이며 ( ) 외는 소시리즈 공통입니다.

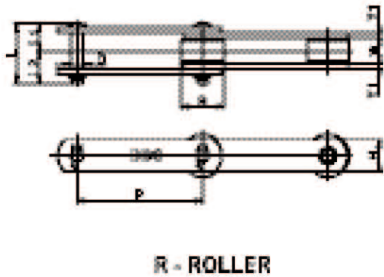

### DBC 26200-R A-2 2L

- Spacing of Attachment (every second link)  
어태치먼트 부착 간격 (2링크마다)
- Type of Attachment (A-2 Attachment)  
어태치먼트 타입 (A-2형)
- Roller Type (R-Roller Type) 로울러타입 (R-Roller Type)
- Chain Size 체인사이즈
- Dong Bo Chain 동보체인

## Roller Dimensions

unit : mm

DONG BO Chain No.		Roller Dimensions													Weight of Rollers (kg/m)			
Basic Chain No.	Roller Type	R-Roller		F-Roller					S-Roller		M-Roller		N-Roller		R-R/o□	F-R/o	S-R/o	M,N-R/o
		R	E	R	F	E	e	Z	R	E	R	E	R	E				
DBC 03075 03100 03150	R · F · S	31.8	15.5	31.8	42	12	1.8	4.3	15.9	15.5	-	-	-	-	2.7 2.3	2.8 2.4	1.9 1.7	-
DBC 430	R · S	38.1	19	-	-	-	-	-	20.1	19	-	-	-	-	4.3	-	3.0	-
DBC 05075 05100 05150	S R · F · S R · F · S	40	19	40	50	14	2.5	4.5	22.2	19	-	-	-	-	5.0 4.5 4.1	5.2 4.6 4.2	4.2 3.7 3.2	-
DBC 204	S	-	-	-	-	-	-	-	22.2	23	25.4	23	-	-	-	-	5.6	-
DBC 450	R · F · S · M	44.5	23	44.5	55	18	2.5	6.5	22.2	23	25.4	23	-	-	6.8	7.5	4.6	4.8
DBC 08125 08150	R · F · S · M	44.5	23	44.5	55	18	2.5	6.5	22.2	23	25.4	23	-	-	5.5	5.8	4.0	4.2
DBC 650	R · F · S · M	50.8	26	50.8	65	20	3	7	25.4	26	31.8	26	-	-	7.7	8.0	6.0	6.4
DBC 10100 10125 10150	R · S · M R · F · S · M R · F · S · M	50.8	27	50.8	65	20	3	7	29	27	31.8	27	-	-	9.8 8.7 7.9	8.9 8.1	6.8 6.3 5.9	7.1 6.5 6.1
DBC 214	R · S · M	44.5	27	-	-	-	-	-	31.8	27	34.9	27	-	-	10.4	-	8.7	9.1
DBC 205	S	-	-	-	-	-	-	-	31.8	27	-	-	-	-	-	-	10.4	-
DBC 6205	R · F · S · M	57.2	32	57.2	70	25	3.5	9	34.9	32	38.1	32	-	-	12.1	12.4	9.3	9.6
DBC 12200 12250	R · F · S · M	65	32	65	80	24	4	8	34.9	32	38.1	32	-	-	11.4 10.3	11.9 10.6	8.4 7.8	8.7 8.0
DBC 17200 17250 17300	R · F · S · M	80	44	80	100	34	5	12	40.1	44	44.4	44	-	-	18.8 16.5 15.0	19.8 17.3 15.7	12.0 11.1 10.5	12.6 11.6 10.9
DBC 212	R · S · M	69.9	32.5	-	-	-	-	-	40.1	32.5	44.4	32.5	-	-	17.1	-	12.6	13.1
DBC 26200 26250 26300 26450	S · M R · F · S · M R · F · S · M R · F · S · M	100	50	100	125	38	6	13	44.5	50	50.8	50	-	-	- 25.3 22.3 18.0	- 26.2 23.6 18.9	16.0 14.7 13.8 12.4	17.0 15.5 14.5 12.9
DBC 36250 36300 36450 36600	S · M R · F · S · M R · F · S · M R · F · S · M	125	56	125	150	42	7	14	50.8	56	57.2	56	57.2	65	39.0 30.7 26.9	40.1 31.9 27.8	24.4 22.9 20.2 18.0	25.5 23.8 20.8 19.5
DBC 52300 52450 52600	R · F · S	140	65	140	170	49	8	16.5	57.2	65	-	65	-	-	48.8 37.5 32.9	52.5 39.3 34.3	29.7 26.2 24.4	- - -
DBC 60300 60350 60400	R · F · N	140	68	140	170	49	8	16.5	-	-	-	68	70	75	52.4 47.2 43.8	55.1 49.5 45.8	- - -	31.0 28.8 27.7
DBC 90350 90400 90500	N R · F · N R · F · N	170	76	170	205	56	10	18	-	-	-	76	85	86	66.9 59.0	71.6 62.8	- -	42.4 40.8 38.1
DBC 120400 120600	R · N R · F · N	200	87	200	240	64	11.5	20.5	-	-	-	87	100	97	105.7 83.3	- 88.0	- -	63.9 55.4

□R/o=Roller





## Attachments for Standard Conveyor Chains

### 표준형 컨베이어 체인의 어태치먼트

#### A-1 Attachment

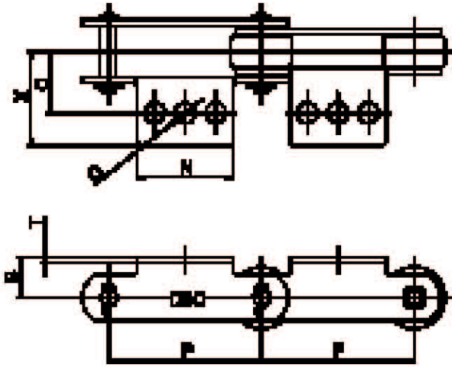

unit : mm

DONG BO Chain No.		Pitch P	Dimensions						Add. Weight per Att. (kg)
Basic Chain No.	Roller Type		S	C	X	N	T	O	
DBC 03075	R · F · S	75							0.05
DBC 03100	R · F · S	100	20	30	46	65	3.2	10	0.06
DBC 430	R · S	101.6	22	40	54	70	4.8(5.0)	12	0.11
DBC 05075	S	75							0.03
DBC 05100	R · F · S	100	22	35	47	65	4.5	10	0.08
DBC 05150	R · F · S	150							0.10
DBC 204	S	66.27	24	45	59	35	6.3(6.0)	12	0.08
DBC 450	R · F · S · M	101.6	28	50	64	70	6.3(6.0)	12	0.18
DBC 08150	R · F · S · M	150	28	50	64	90	6.3(6.0)	12	0.22
DBC 650	R · F · S · M	152.4	32	50	64	90	6.3(6.0)	12	0.22
DBC 10100	R · F · S · M	100	28	50	65	70	6.3(6.0)	12	0.16
DBC 10150	R · F · S · M	150							0.20
DBC 214	R · S · M	101.6	35	55	73	80	7.9	15	0.28
DBC 6205	R · F · S · M	152.4	38	60	79	100	7.9	15	0.37
DBC 12200	R · F · S · M	200							0.45
DBC 12250	R · F · S · M	250	38	60	79	120	7.9	15	0.62
DBC 212	R · S · M	152.4	45	65	83	100	9.5(10.0)	15	0.49
DBC 17200	R · F · S · M	200	45	75	98	120	9.5(10.0)	15	0.66
DBC 17250	R · F · S · M	250							0.79

#### A-2 Attachment

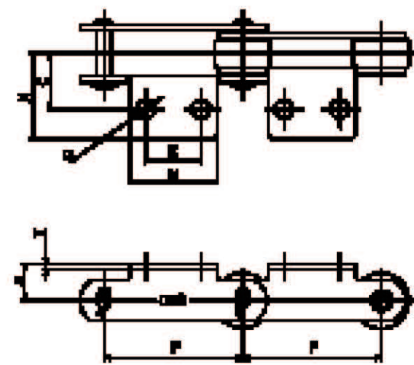

unit : mm

DONG BO Chain No.		Pitch P	Dimensions							Add. Weight per Att. (kg)
Basic Chain No.	Roller Type		S	C	X	N	K	T	O	
DBC 03075	R · F · S	75								0.05
DBC 03100	R · F · S	100	20	30	46	65	40	3.2	10	0.06
DBC 430	R · S	101.6	22	40	54	70	40	4.8(5.0)	12	0.11
DBC 05075	S	75								0.07
DBC 05100	R · F · S	100	22	35	47	65	40	4.5	10	0.08
DBC 05150	R · F · S	150								0.10
DBC 204	S	66.27	24	45	59	55	35	6.3(6.0)	12	0.13
DBC 450	R · F · S · M	101.6	28	50	64	70	40	6.3(6.0)	12	0.18
DBC 08150	R · F · S · M	150	28	50	64	90	60	6.3(6.0)	12	0.22
DBC 650	R · F · S · M	152.4	32	50	64	90	60	6.3(6.0)	12	0.22
DBC 10100	R · S · M	100	28	50	65	70	40	6.3(6.0)	12	0.16
DBC 10150	R · F · S · M	150								0.20
DBC 214	R · S · M	101.6	35	55	73	80	40	7.9	15	0.28
DBC 205	S	78.11	35	60	75	65	30	7.9	12	0.23
DBC 6205	R · F · S · M	152.4	38	60	79	100	60	7.9	15	0.37
DBC 12200	R · F · S · M	200								0.45
DBC 12250	R · F · S · M	250	38	60	79	120	80	7.9	15	0.62
DBC 212	R · S · M	152.4	45	65	83	100	60	9.5(10.0)	15	0.49
DBC 17200	R · F · S · M	200	45	75	98	120	80	9.5(10.0)	15	0.66
DBC 17250	R · F · S · M	250								0.79
DBC 26200	S · M	200	55	80	108	120	80	9.5(10.0)	15	0.78
DBC 26250	R · F · S · M	250	55	80	108	165	125	9.5(10.0)	15	1.07

Note)

1. Numbers of Plate in brackets indicates the Stainless steel 300 Series.
2. X figures are approximations. Please inquire when chain apply under lateral usage and interference.

주)

1. 링크플레이트 ( )내 치수는 스테인레스 300시리즈임.
2. X 치수는 개략치이며, 측면사용 혹은 간섭발생 조건일 경우에는 문의하여 주십시오.

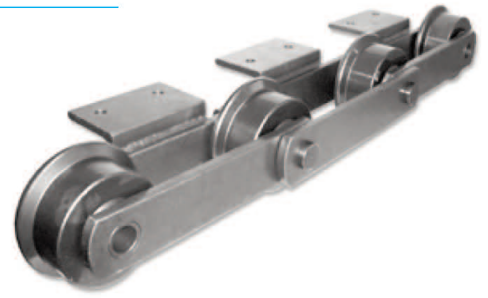

unit : mm

### A-2 Attachment (Welded Type : 용접형)

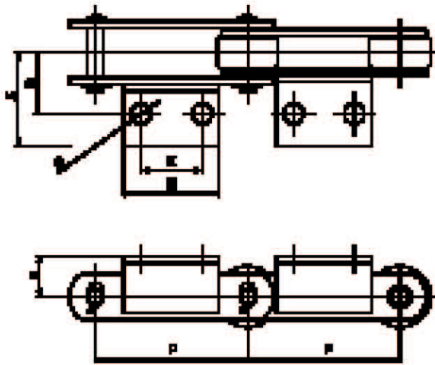

DONG BO Chain No.		Pitch P	Dimensions							Compatible Angle□	Add. Weight per Att□ (kg)
Basic Chain No.	Roller Type		S	C	X	N	K	O			
<b>DBC 17300</b>	R · F · S · M	300	45	75	110.5	220	180	15	L65×65×6	1.34	
<b>DBC 26300</b> <b>26450</b>	R · F · S · M R · F · S · M	300 450	55	80	123.5	220 320	180 280	15	L75×75×9	2.22 3.26	
<b>DBC 36300</b> <b>36450</b> <b>36600</b>	R · F · S · M R · F · S · M R · F · S · M	300 450 600	70	100	160	160 330 410	100 280 360	19	L100×100×10	2.50 5.07 6.26	
<b>DBC 52300</b> <b>52450</b> <b>52600</b>	R · F · S R · F · S R · F · S	300 450 600	80	120	171.4	160 330 410	100 280 360	24	L100×100×13	3.10 6.30 7.80	
<b>DBC 60300</b> <b>60350</b> <b>60400</b>	R · F · N R · F · N R · F · N	300 350 400	90	115	165	170 220 260	110 160 200	24	L100×100×13	3.30 4.20 6.00	
<b>DBC 90350</b> <b>90400</b> <b>90500</b>	N R · F · N R · F · N	350 400 500	100	140	210	180 230 340	100 150 260	28	L130×130×15	5.20 6.60 9.80	
<b>DBC 120400</b> <b>120600</b>	R · N R · F · N	400 600	120	150	220	200 400	120 320	28	L130×130×15	5.80 11.50	

### A-3 Attachment (Welded Type : 용접형)

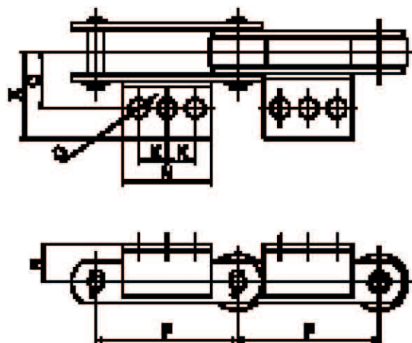

unit : mm

DONG BO Chain No.		Pitch P	Dimensions							Compatible Angle□	Add. Weight per Att□ (kg)
Basic Chain No.	Roller Type		S	C	X	N	K	O			
<b>DBC 26450</b>	R · F · S · M	450	55	80	123.5	320	140	15	L75×75×9	3.26	
<b>DBC 36450</b> <b>36600</b>	R · F · S · M R · F · S · M	450 600	70	100	160	330 410	140 180	19	L100×100×10	5.07 6.26	
<b>DBC 52450</b> <b>52600</b>	R · F R · F	450 600	80	120	171.4	330 410	140 180	24	L100×100×13	6.30 7.80	
<b>DBC 60350</b> <b>60400</b>	R · F · N R · F · N	350 400	90	115	165	220 260	80 100	24	L100×100×13	4.20 6.00	
<b>DBC 90500</b>	R · F · N	500	100	140	210	340	130	28	L130×130×15	9.80	
<b>DBC 120600</b>	R · F · N	600	220	150	220	400	160	28	L130×130×15	11.50	

□Compatible Angle=사용앵글

Note)

1. The Stainless steel Series uses different angle figures. Please inquire.
2. X figures are approximations, Please inquire when chain apply under lateral usage and interference.

주)

1. 스테인레스 시리즈는 사용 앵글치수가 다르므로 문의하여 주십시오.
2. X 치수는 개략치이며, 측면사용 혹은 간섭발생 조건일 경우에는 문의하여 주십시오.

## Attachments for Standard Conveyor Chains

### 표준형 컨베이어 체인의 어태치먼트

#### K-1 Attachment

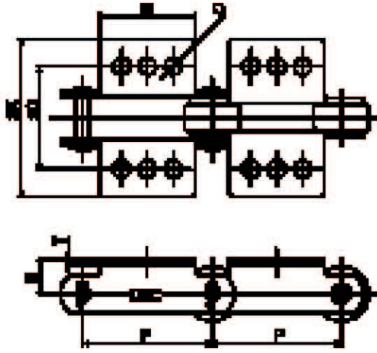

unit : mm

DONG BO Chain No.		Pitch P	Dimensions						Add. Weight per Att.□ (kg)	
Basic Chain No.	Roller Type		S	C	X	N	T	O		
DBC 03075 03100	R · F · S	75	20	60	92	55	3.2	10	0.10	
	R · F · S	100				65				
DBC 430	R · S	101.6	22	80	108	70	4.8(5.0)	12	0.22	
DBC 05075 05100 05150	S	75	22	70	94	55	4.5	10	0.06	
	R · F · S	100				65				0.16
	R · F · S	150				85				
DBC 204	S	66.27	24	90	118	35	6.3(6.0)	12	0.16	
DBC 450	R · F · S · M	101.6	28	100	128	70	6.3(6.0)	12	0.36	
DBC 08150	R · F · S · M	150	28	100	128	90	6.3(6.0)	12	0.44	
DBC 650	R · F · S · M	152.4	32	100	128	90	6.3(6.0)	12	0.44	
DBC 10100 10150	R · S · M	100	28	100	130	70	6.3(6.0)	12	0.32	
	R · F · S · M	150				90				0.40
DBC 214	R · S · M	101.6	35	110	146	80	7.9	15	0.56	
DBC 6205	R · F · S · M	152.4	38	120	158	100	7.9	15	0.74	
DBC 12200 12250	R · F · S · M	200	38	120	158	120	7.9	15	0.90	
	R · F · S · M	250				165				1.24
DBC 212	R · S · M	152.4	45	130	166	100	9.5(10.0)	15	0.98	
DBC 17200 17250	R · F · S · M	200	45	150	196	120	9.5(10.0)	15	1.32	
	R · F · S · M	250				165				1.58

#### K-2 Attachment

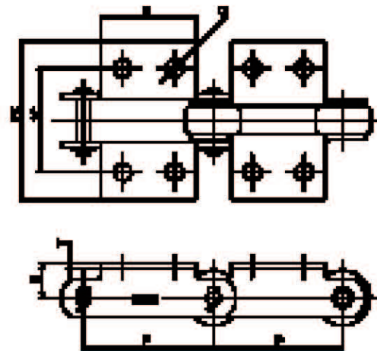

unit : mm

DONG BO Chain No.		Pitch P	Dimensions						Add. Weight per Att.□ (kg)		
Basic Chain No.	Roller Type		S	2C	2X	N	K	T		O	
DBC 03075 03100	R · F · S	75	20	60	92	55	30	3.2	10	0.10	
	R · F · S	100				65	40				
DBC 430	R · S	101.6	22	80	108	70	40	4.8(5.0)	12	0.22	
DBC 05075 05100 05150	S	75	22	70	94	55	30	4.5	10	0.14	
	R · F · S	100				65	40				0.16
	R · F · S	150				85	60				
DBC 204	S	66.27	24	90	118	55	35	6.3(6.0)	12	0.26	
DBC 450	R · F · S · M	101.6	28	100	128	70	40	6.3(6.0)	12	0.36	
DBC 08150	R · F · S · M	150	28	100	128	90	60	6.3(6.0)	12	0.44	
DBC 650	R · F · S · M	152.4	32	100	128	90	60	6.3(6.0)	12	0.44	
DBC 10100 10150	R · S · M	100	28	100	130	70	40	6.3(6.0)	12	0.32	
	R · F · S · M	150				90	60				0.40
DBC 214	R · S · M	101.6	35	110	146	80	40	7.9	15	0.56	
DBC 205	S	78.11	35	120	150	65	30	7.9	12	0.46	
DBC 6205	R · F · S · M	152.4	38	120	158	100	60	7.9	15	0.74	
DBC 12200 12250	R · F · S · M	200	38	120	158	120	80	7.9	15	0.90	
	R · F · S · M	250				165	125				1.24
DBC 212	R · S · M	152.4	45	130	166	100	60	9.5(10.0)	15	0.98	
DBC 17200 17250	R · F · S · M	200	45	150	196	120	80	9.5(10.0)	15	1.32	
	R · F · S · M	250				165	125				1.58
DBC 26200 26250	S · M	200	55	160	216	120	80	9.5(10.0)	15	1.56	
	R · F · S · M	250				160	216				165

Note)

- Numbers of Plate in brackets indicates the Stainless steel 300 Series.
- X figures are approximations, Please inquire when chain apply under lateral usage and interference.

주)

- 링크플레이트 ( )내 치수는 스테인레스 300시리즈임.
- X, 2X 치수는 개략치이며, 측면사용 혹은 간섭발생 조건일 경우에는 문의하여 주십시오.



## SA-2 Attachment

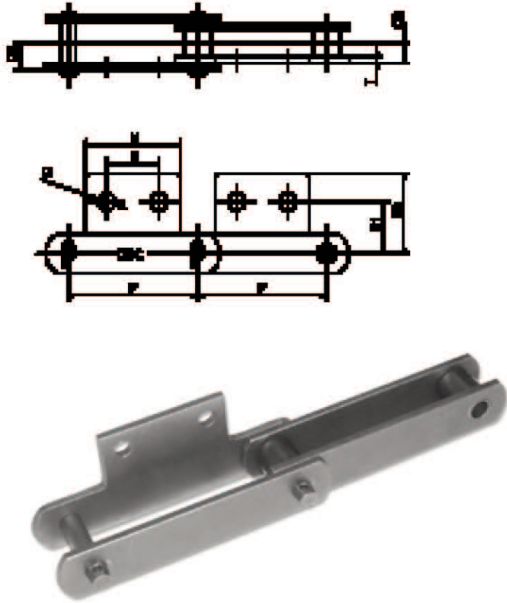

unit : mm

DONG BO Chain No.		Pitch	Dimensions								Add. Weight per Att. (kg)
Basic Chain No.	Roller Type		P	S <sub>1</sub>	S <sub>2</sub>	Q <sub>1</sub>	Q <sub>2</sub>	K	N	T	
DBC 03075	R · S	75	33	49	15.5	11.5	30	55	3.2	10	0.05
DBC 03100	R · S	100	33	49	15.5	11.5	40	65	3.2	10	0.06
DBC 430	R · S	101.6	37.6	51.6	22(22.5)	16(16.5)	40	70	4.8(5.0)	12	0.11
DBC 05100	R · S	100	33.4	50.7	21	15.5	40	65	4.5	10	0.08
DBC 05150	R · S	150	33.4	50.7	21	15.5	60	85	4.5	10	0.10
DBC 450	R · S · M	101.6	47.6	60.7	27(26.5)	20(19.5)	40	70	6.3(6.0)	12	0.18
DBC 08150	R · S · M	150	46.1	58.7	27(26.5)	20(19.5)	60	90	6.3(6.0)	12	0.22
DBC 650	R · S · M	152.4	50	63	28.5(28)	21.5(21)	60	90	6.3(6.0)	12	0.22
DBC 10100	R · S · M	100	46.1	61	28.5(28)	21.5(21)	40	70	6.3(6.0)	12	0.16
DBC 10150	R · S · M	150	46.1	61	28.5(28)	21.5(21)	60	90	6.3(6.0)	12	0.20
DBC 214	R · S · M	101.6	50	70	32.5	23.5	40	80	7.9	15	0.28
DBC 6205	R · S · M	152.4	55	75.7	35.5	26.5	60	100	7.9	15	0.37
DBC 12200	R · S · M	200	55	75.7	35.5	26.5	80	120	7.9	15	0.45
DBC 12250	R · S · M	250	55	75.7	35.5	26.5	125	165	7.9	15	0.62
DBC 212	R · S · M	152.4	60	83.6	38(39.5)	28(28.5)	60	100	9.5(10.0)	15	0.49

## SK-2 Attachment

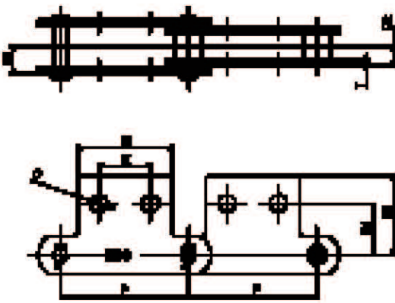

unit : mm

DONG BO Chain No.		Pitch	Dimensions								Add. Weight per Att. (kg)
Basic Chain No.	Roller Type		P	S <sub>1</sub>	S <sub>2</sub>	Q <sub>1</sub>	Q <sub>2</sub>	K	N	T	
DBC 03075	R · S	75	33	49	15.5	11.5	30	55	3.2	10	0.10
DBC 03100	R · S	100	33	49	15.5	11.5	40	65	3.2	10	0.12
DBC 430	R · S	101.6	37.6	51.6	22(22.5)	16(16.5)	40	70	4.8(5.0)	12	0.22
DBC 05100	R · S	100	33.4	50.7	21	15.5	40	65	4.5	10	0.16
DBC 05150	R · S	150	33.4	50.7	21	15.5	60	85	4.5	10	0.20
DBC 450	R · S · M	101.6	47.6	60.7	27(26.5)	20(19.5)	40	70	6.3(6.0)	12	0.36
DBC 08150	R · S · M	150	46.1	58.7	27(26.5)	20(19.5)	60	90	6.3(6.0)	12	0.44
DBC 650	R · S · M	152.4	50	63	28.5(28)	21.5(21)	60	90	6.3(6.0)	12	0.44
DBC 10100	R · S · M	100	46.1	61	28.5(28)	21.5(21)	40	70	6.3(6.0)	12	0.32
DBC 10150	R · S · M	150	46.1	61	28.5(28)	21.5(21)	60	90	6.3(6.0)	12	0.40
DBC 214	R · S · M	101.6	50	70	32.5	23.5	40	80	7.9	15	0.56
DBC 6205	R · S · M	152.4	55	75.7	35.5	26.5	60	100	7.9	15	0.74
DBC 12200	R · S · M	200	55	75.7	35.5	26.5	80	120	7.9	15	0.90
DBC 12250	R · S · M	250	55	75.7	35.5	26.5	125	165	7.9	15	1.24
DBC 212	R · S · M	152.4	60	83.6	38(39.5)	28(28.5)	60	100	9.5(10.0)	15	0.98

Note)  
Numbers of Plate in brackets indicates the Stainless steel 300 Series.

주)  
링크플레이트 ( ) 내 치수는 스테인레스 300시리즈임.

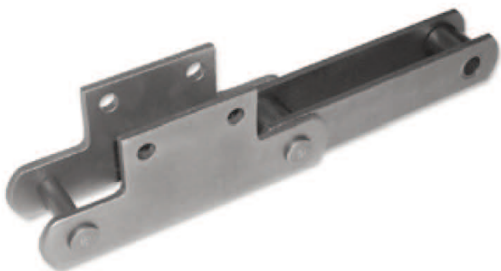



## Attachments for Standard Conveyor Chains

### 표준형 컨베이어 체인의 어태치먼트

#### G-2 Attachment

unit : mm

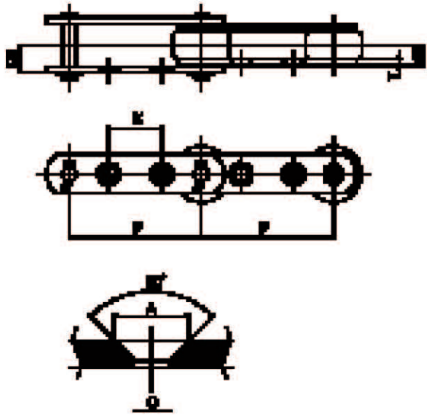

DONG BO Chain No.		Pitch P	Dimensions					
Basic Chain No.	Roller Type		K	T	Q1	Q2	A	O
DBC 03075 03100	R · S	75	30	3.2	15.5	11.5	13.5	8
	R · F · S	100	50					
DBC 05100 05150	R · S	100	40	4.5	21	15.5	15	10
	R · F · S	150	60					
DBC 08150	R · F · S · M	150	60	6.3	27	20	20	12
DBC 650	R · F · S · M	152.4	60	6.3(6)	28.5(28)	21.5(21)	20	12
DBC 10100 10150	S · M	100	30	6.3(6)	28.5(28)	21.5(2.1)	20	12
	R · F · S · M	150	60					
DBC 6205	R · F · S · M	152.4	50	7.9	35.5	26.5	26	15
	R · F · S · M	200	80	7.9	35.5	26.5	26	15
DBC 12200 12250 12300	R · F · S · M	200	70					
	R · F · S · M	250	110	9.5(10.0)	45.5(46.5)	35(35.5)	26	15
	R · F · S · M	300	150					
DBC 26300 26450	R · F · S · M	300	140	9.5(10.0)	48(49)	38(38.5)	26	15
	R · F · S · M	450	220					
DBC 36450 36600	R · F · S · M	450	220	12.7	60	46	32	19
	R · F · S · M	600	300					
DBC 52450 52600	R · F · S	450	200	16	71.5	45.5	38	24
	R · F · S	600	300					

#### G-4 Attachment

unit : mm

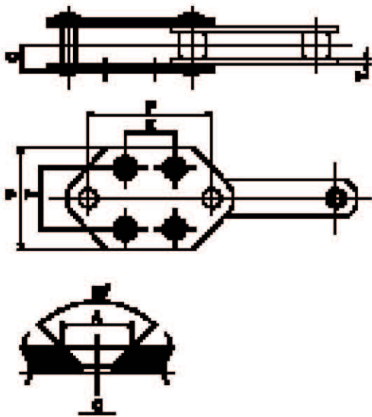

DONG BO Chain No.		Pitch P	Dimensions							Add. Weight per Att. × 2L (kg/m) □
Basic Chain No.	Roller Type		V	K	Y	T	Q	A	O	
DBC 05100 05150	S	100	80	50	50	4.5	21	15	10	4.6
	S	150	70	70						4.1
DBC 650	S · M	152.4	110	75	70	6.3	28.5	20	12	7.2(7.6)
DBC 10150	S · M	150	110	75	70	6.3	28.5	20	12	7.2(7.4)
DBC 6205	S · M	152.4	110	75	70	7.9	35.5	26	15	11.0(11.3)
DBC 12200	S · M	200	110	100	70	7.9	35.5	26	15	10.2(10.5)
DBC 17200 17250	S · M	200	120	100	80	9.5	45.5	26	15	14.0(14.6)
	S · M	250	150	140	100					14.5(15.0)
DBC 26200 26250 26300	S · M	200	120	100	80					17.5(18.5)
	S · M	250	150	140	100	9.5	48	26	15	17.6(18.4)
	S · M	300	150	180	100					16.7(17.4)
DBC 36250 36300	S · M	250	150	140	100	12.7	60	32	19	27.6(28.6)
	S · M	300	180							26.2(27.1)

- Add. Weight per Att. = additional Weight per Attachment at every second link spacing
- 2링크마다 어태치먼트 부착시의 중량(kg/m)