

Standard Conveyor Chain II (Bushed Type) 표준형 컨베이어 체인 II (부쉬드타입)

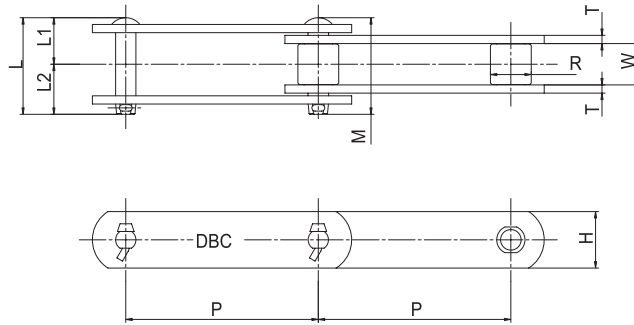

unit : mm

DONG BO Chain No.	Pitch P	Bushing		Pin			Plate		Arg. Breaking Load (kgf)	max. Allowable Load (kgf)	Weight (kg/m)	
		Dia. R	Inner Width W	Dia. D	Length			Thick-ness T				Heigh H
					L	L1	L2					
DBC B204	66.27	22.2	27.0	11.10	64.5	29.5	35.0	6.3	28.6	8,000	750	5.6
DBC B205	78.11	31.8	36.5	14.30	85.0	38.7	46.3	7.9	38.1	14,000	1,300	10.3
DBC B05101	101.60	18.2	22.2	9.54	51.2	23.9	27.3	4.8	25.4	5,500	500	2.9
DBC B16103	103.20	44.5	44.5	19.10	97.5	44.5	53.0	7.9	50.8	19,000	2,250	15.1
DBC B07100	100	20.0	22.2	11.10	53.4	24.2	29.2	4.8	31.8	7,500	600	3.6
DBC B10100	100	25.4	30.0	14.30	70.0	32.2	37.8	6.3	38.3	11,500	1,050	6.7
DBC B10150	150	25.4	30.0	14.30	70.0	32.2	37.8	6.3	38.1	11,500	1,050	5.7

Attachments for Standard Conveyor Chain II (Bushed Type)

표준형 컨베이어 체인 II (부쉬드타입) 어태치먼트

A-1 Attachment

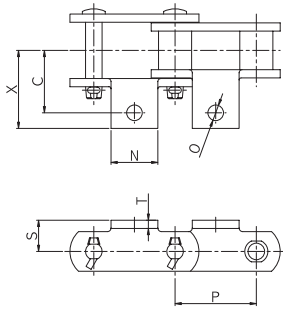

K-1 Attachment

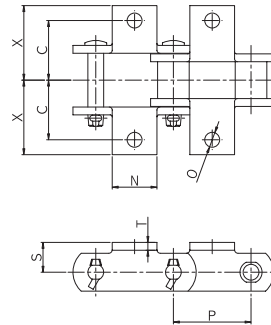

unit:mm

DONG BO Chain No.	Pitch P	Dimensions						add.Weight per Attachment. (kg/each)
		S	C	X	N	T	O	
DBC B204	66.27	24	45	64	35	6.3	11	0.10 (0.20)
DBC B205	78.11	35	60	87	45	7.9	12	0.15 (0.30)

A-2 Attachment

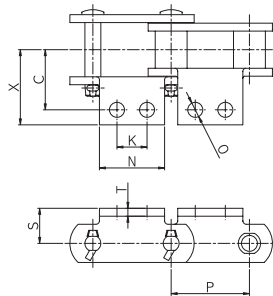

K-2 Attachment

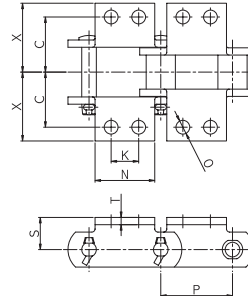

unit:mm

DONG BO Chain No.	Pitch P	Dimensions							add.Weight per Attachment. (kg/each)
		S	C	X	N	K	T	O	
DBC B204	78.11	35	60	79	79	65	7.9	12	0.25 (0.50)
DBC B07100	100.00	12	35	47	65	47	4.8	9.5	0.10 (0.20)
DBC B10100	100.00	28	50	64	70	64	6.3	11	0.10 (0.30)
DBC B10150	150.00	28	50	66	90	66	6.3	11	0.20 (0.40)

G-2 Attachment

unit:mm

DONG BO Chain No.	Pitch P	Dimensions				
		K	T	Q ₁	Q ₂	d
DBC B07100	100	40	4.8	20.9	15.8	9.5
DBC B10100	100	35	6.3	28.1	21.3	11
DBC B10150	150	60	6.3	28.1	21.3	11

